

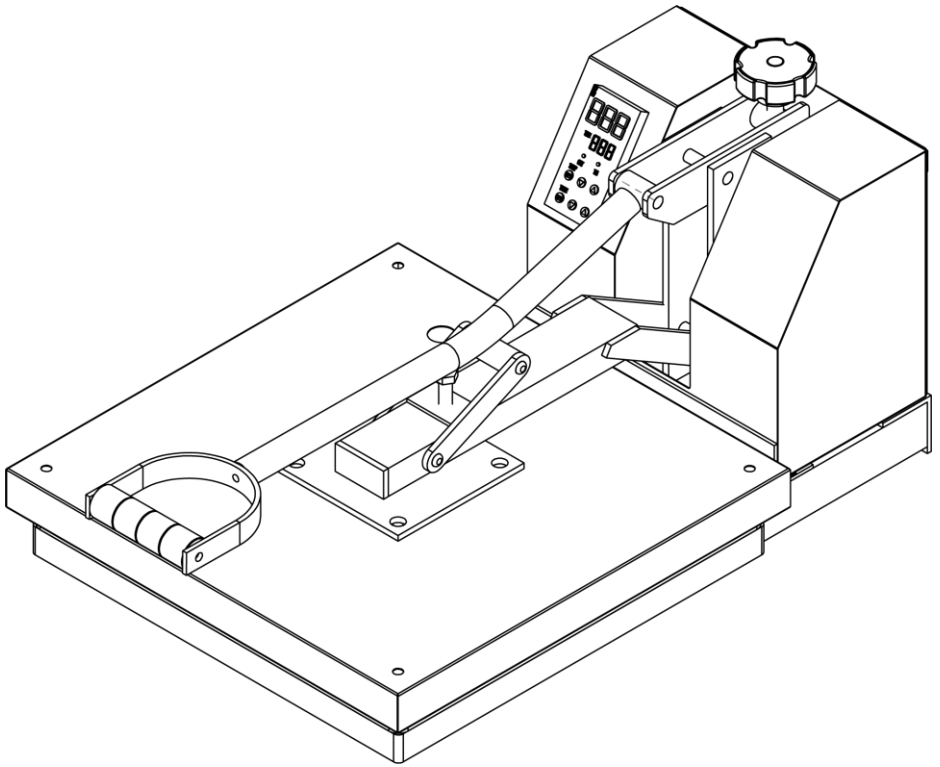

15" x 15" Clamshell Heat Press Machine

USER MANUAL



Machine Introduction

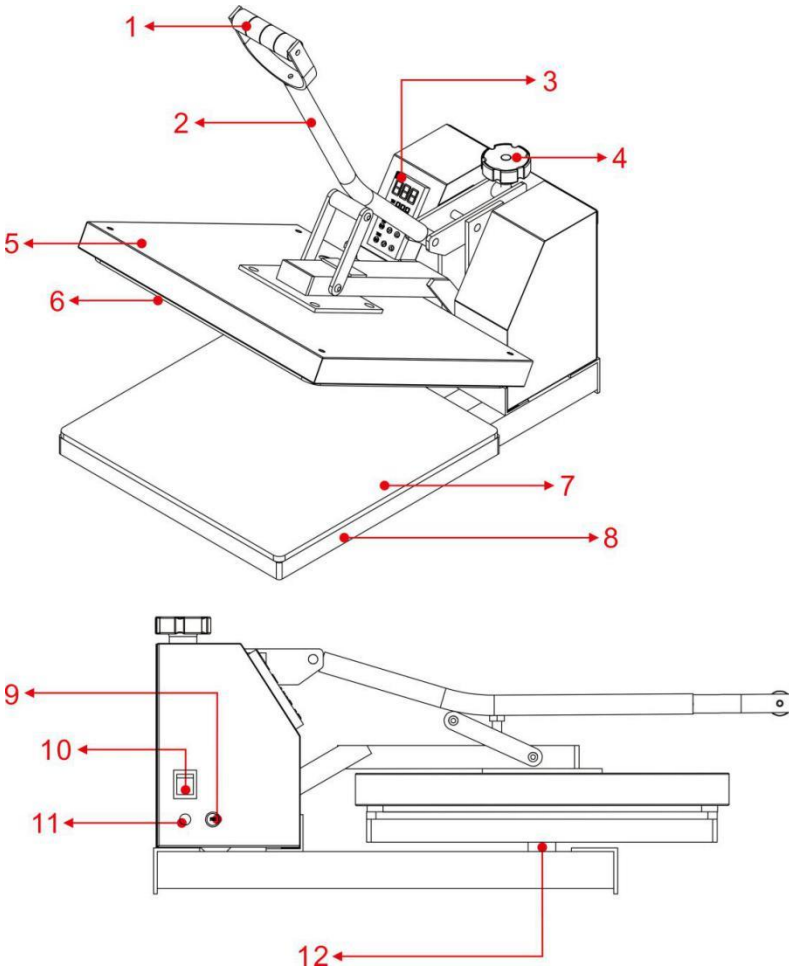

1.Pressure Handle

2.Pressure Handle Grip

3.Temp/Time Controller

4.Pressure Adjustment Knob

5.Anti-scald Protective Cover

6.Aluminum Heating Plate

7.High-temp Resistant Silicone Pad

8.Work Table

9.Fuse

10.Power Switch

11.Power Cord Socket

12.Base Plate

Applications

- ① **Textiles**: T-shirts, Fabrics, Pillows, Bags, Mouse Pads, etc.
- ② **Sublimation Coated Hard Goods** : Ceramics, Stone Slate, MDF Blank, Tile, Key Chain, Metal sheet, etc.

Features

1. **Temp/Time Controller**: Displays temperature and countdown timer with audio completion alert.
2. **Bottom of Heating Plate**: The bottom of heating plate is covered by a Teflon paint to ensure durability and easy clean up.
3. **Pressure Adjustment Knob**: Turn the knob to increase or reduce the pressure based on the materials being used.
4. **Removable High Temperature Resistant Silicone Pad**: The Silicone pad provides proper heat conduction to ensure high quality transfers and HTV adhesion. The silicone pad can withstand temperatures over 750°F / 400°C.
5. **Rapid Heating**: The heating tube is connected to the heating plate, which can heat the work surface in a short time improving work efficiency.

Technical Parameter

Heating Plate (Teflon Coated): 15 x 15inch / 38 x 38cm

Voltage: 110V Power: 1300W

Temp Range: 0-480°F / 0-250°C Heating Up Time: 5-15 minutes

Time Range: 0-499 s Gross Weight: 55lb / 25kg

Before Using

- 1. Please keep out of the reach of children and read the whole instruction manual carefully.**
2. Ensure that the quality of the power outlet used is up to code, the maximum power is greater than the power of the machine.
3. Every time the machine is turned on, the heating plate must be preheated for a period of time to reach the target temperature. The first warm-up may take 20 minutes to reach 360°F/ 180°C. It is recommended to test on a scrap piece of material prior to first use. After finishing any project, turn off and unplug the heat press.

Maintenance and care of the machine

- a. Do not touch the heat plate when the machine is on or after use. The plate can get very hot, allow ample time for the plate to cool after use.
- b. Don't let the power cord touch the heating plate.
- c. Don't set the temperature above **400°F / 210°C** for a long time, and don't set the time above **200s** for a long time, which will help extend the life of the machine.
- d. Keep the machine dry, do not store in an area with high humidity.
- e. Ensure the machine is fully cooled before moving, packaging, or storage.
- f. Turn off for 15 minutes after 4 hours of continuous use.
- g. Don't operate other high-power equipment on the same circuit.
- h. Do not use for food processing or any other unintended use.
- i. Do not disassemble the heat press.
- j. Please do not operate heat press with a damaged cord or when the equipment has been broken.
- k. Please do not immerse the heat press in water or other liquid.
- l. In case of thunderstorms / adverse working conditions, please turn the machine off and unplug from the outlet.
- m. When not in use, store heat press open.

Kindly Note: Don't copy, modify or transfer any content of this manual in any name.

Suggested Temp and Time

***Always check manufacture recommended time and temperature for the transfer material you are using**

Substrate	Temperature	Time(s)	Attention
Polyester	360°F / 180°C	25-30	Sublimation paper, sublimation ink, print Mirror Mode, Heavy Pressure
Dark Cotton	330°F / 165°C	25-30	Dark transfer paper, print non-Mirror Mode Remove Backing, place the patterned side up, Heavy Pressure
Light Cotton	330°F / 165°C	25-30	Light transfer paper, print Mirror Mode. Place design facedown, Heavy Pressure
HTV Vinyl Film	290°F / 145°C	10-15	Cut material side up using Mirror Mode with a vinyl cutter (ensure you do not cut through the clear heat resistant transfer tape backing), weed excess vinyl, place design down on garment utilizing the heat resistant transfer tape. Normal Pressure
Mouse Pad	380°F / 190°C	30-40	Sublimation paper, sublimation ink, print Mirror Mode, Heavy Pressure
MDF Blank (0.3cm Thick)	360°F / 180°C	30-40	Sublimation paper, sublimation ink, print Mirror Mode, Reverse baking (Substrate face down) Heavy Pressure

MDF Blank (1.2cm Thick)	360°F / 180°C	150-170	Sublimation paper, sublimation ink, print Mirror Mode, Reverse baking (Substrate face down) Heavy Pressure
Stone Slate	360°F / 180°C	180-190	Sublimation paper, sublimation ink, print Mirror Mode, Reverse baking (Substrate face down) Low Pressure
Aluminum Sheet	360°F / 180°C	20-25	Sublimation paper, sublimation ink, print Mirror Mode, Heavy Pressure , Remove the protective film from the plate before application
Porcelain Board	360°F / 180°C	240-360	Sublimation paper, sublimation ink, print Mirror Mode, Reverse baking (Substrate face down) Heavy Pressure
High-temp Resistant Puzzle	360°F / 180°C	30-40	Sublimation paper, sublimation ink, print Mirror Mode, Normal Pressure

Operation Process

1.Adjust the pressure

- ① Before starting, use the pressure knob to adjust the pressure between the heating plate and the bottom plate.
- ② Turn clockwise to increase pressure, turn counterclockwise to reduce pressure.
- ③ When adjusting the pressure, place the substrate on the silicone pad. Pull the handle down and find the suitable pressure (Textiles may need more pressure). Adjust the pressure knob as needed.

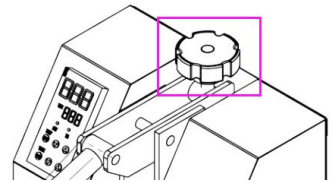

2. Connect the power

- ① Check the power cord and machine appearance, make sure press is on a flat level surface.
- ② Connect the power cord to a grounded outlet with sufficient current and power.
- ③ Turn the power on to light up the panel.

3. Panel Setting

OUT: Heating Indicator Light

TIME: Countdown Time Indicator Light

- ① Setting the Target Temperature: Press the TEMP "SET" key and the panel shows will show "SP". Press the ▲ (up) or ▼ (down) to set the temperature. You may refer to the "**Suggested Time and Temperature**" table to determine the suitable temperature and time according to the materials you intend to use.

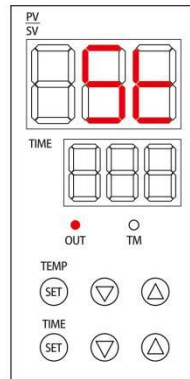
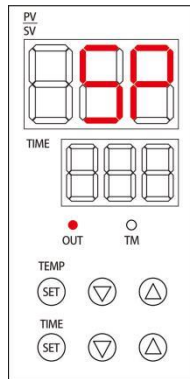

- ② Press the TEMP "SET" again for two seconds to save the temperature settings.
- ③ Setting the Target Time: Press the TIME "SET" key and the panel will display "SL". Press the ▲ (up) or ▼ (down) to adjust the time.
- ④ Press the TIME "SET" again for two seconds to save the time settings.
- ⑤ Working Temperature: After you save the target temperature and time, the panel will show the working temperature, which is the current temperature of the heat plate. The heat plate will take some time to warm up. Please wait until the **working temperature** reaches the **target temperature** - only then the machine is ready to use.

⑥ Adjusting Temperature between Fahrenheit to Celsius

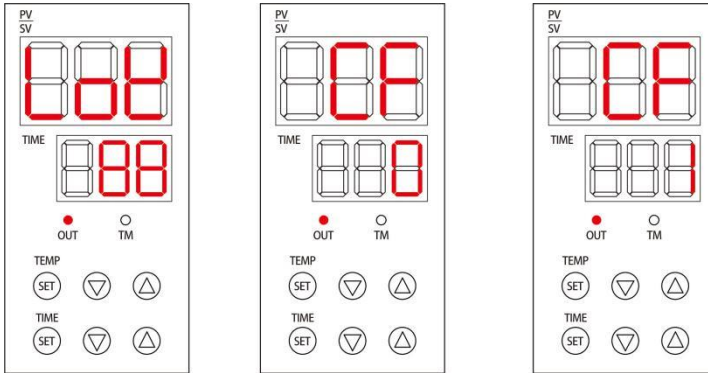

A. Press the TEMP “SET” key until the display shows "LOY"

B. Press button "▼▲" to enter password "88"

C. Press the TEMP “SET” key till the display shows "CF", then press button "▼▲" to transfer Degrees Celsius and Fahrenheit

D. When the display shows "0", it is Celsius

E. When the display shows "1", it is Fahrenheit (if it is Fahrenheit, the temperature is different from Celsius, and the conversion formula is: $^{\circ}\text{F}=1.8^{\circ}\text{C}+32$)

F. Press the TEMP “SET” key for 5s to confirm and log out of the setting

4. Prepare Consumables

① Print sublimation/ transfer paper, cut heat resistant vinyl film, etc.

② After the machine reaches the target temperature, if applying to a fabric pre-press the material for 2s to remove any moisture and wrinkles.

5. Start Transfer

Align substrate and transfer material on bottom plate of press. The transfer media should be placed on top of the substrate so it gets direct heat from the top plate.

Pull down the handle to close the top platen. When the handle is locked down, the timer will start automatically and start countdown.

6. Inspect the Finished Product

Check the transfer. If you are not satisfied, refer to the table to adjust the time and temperature parameters. **Kindly Note: It is always recommended to test on scrap fabric or sublimation blanks prior to creating the final product.**

Troubleshoot

- 1.Light Color Transfer:** Time set too short / Temp too low / Pressure too low. If the room temp is low, please turn up the setting temp. Please check one by one.
- 2.Overall Image Blur:** Time set too long / Pressure too high / Temp too high, which causes the ink to spread / the vinyl film to melt/ the coating of substrate may be uneven, please check one by one.
- 3.Partial Image Blur:** Time is too long / Pressure too high / Temp too high / substrate coating is uneven / moved during transfer, please check one by one.
- 4.Paper Not Releasing from Substrate:** Temp is too high / Pressure too heavy / Substrate coating is thick / Ink is not dry after printing, please check one by one.

Machine Fault Solution

- 1.The machine does not turn on

Check plug / power switch / panel controller / fuse.

2. At the beginning of work, the panel controller does not display the countdown/ after the countdown is completed, the buzzer does not sound

Check the countdown micro-switch.

- 2.Press cannot be opened

① Please adjust the pressure knob counter clockwise to reduce the pressure, pull up on the handle.

- ② If it still cannot be opened, turn on the power switch and set the heating plate with higher temperature, then pull up on the handle.

- 4.After replacing the heating plate, the temp and time become abnormal/ the temp does not increase.

Reset the temp and time.

5.The machine keeps beeping

Press the "ENTER" button, please check if the temperature is too high (Such as incorrect Celsius and Fahrenheit settings), voltage error.

6.After receiving the machine there is a strong odor

After passing the factory startup test, the silicone pad may produce a non-toxic odor, the smell will disappear after using the machine several times.

7.The square plate in the middle of the machine keeps shaking

Tighten the screws which attaches the plate to the press.

8 .Fogging out

Like an iron, when the air humidity is high / the temp difference is high, heating may produce evaporation. This is normal.

9. Part of surface on the machine is rusted

This can happen due to storage of the press. A small area of rust on its surface will not have a negative affect on how the machine works.

10. When the fuse is burnt out

After powering off, use a key to open the fuse panel which is next to the power cord interface and install a new fuse.

For any questions, please [contact the customer service](#) and get professional support.

Keep Tips

1. Keep the machine clean. Dust can damage electronic accessories. Clean the machine and panel controller every six months.

2. Clean the heating plate with a damp soft cloth once a month. If it is difficult to clean, use iron cleaners or mineral alcohol.

3. In order to maintain the good transfer effect of the heating plate, the heating plate needs to be carefully protected during use. It is always recommended to use a heat resistant protectant sheet between the top plate and the project.
4. Lubricate all exposed rods once a year. (WD-40, Oil or any metal lubricant)
5. When the silicone pad / sponge elasticity is insufficient, it should be replaced.

About Sublimation Paper

1. Keep sublimation paper in a dry place. Put the unused paper back in the box. If it is kept outside the box for a long time, the paper may absorb the moisture in the air and curl which can result in poor transfers.

2. **Ink, Printer:** Use sublimation ink & paper for all sublimation blanks. Inkjet ink can be used for printable light and dark heat transfer vinyl only.

3.Applications:

① **Light / White** textiles: Polyester T-shirt, Modal clothing, Flax pillow, Oxford fabric bag, Mouse pad, etc. with at least 65% polyester. **Sublimation paper can't be used on high cotton content textile.**

② **Sublimation Coated Hard Objects:** Stone Slate, MDF Blanks, Tiles, Key Chains, Metal Sheets, etc. Please check whether there is sublimation coating on the hard surface.

4.Transfer process: Select "Mirror Mode" when printing. If the color looks dark after printing, this is normal. Sublimation paper will curl quickly when heated, it is recommended that heat resistant tape is used to hold the sublimation paper to the fabric or sublimation blank.

5.Other questions: Due to the large number of factors involved in sublimation, please check each of the following items:

① Whether the substrate is wet / expired / poor quality, the surface of the hard object must have a sublimation coating.

② **Printer Settings:** Set the paper to "High Quality Plain Paper/Photo Paper", set the quality to "High Quality" and set the speed to "Slowest". Click "More Options" to customize the color correction.

③ Whether the sublimation ink has expired/deteriorated. Ensure the print heads are clean and clear of dried ink.

④ Heat press heating plate is not hot enough/ large temperature fluctuations/ time is not enough / pressure too low. If **360°F/180°C** is set, please use a thermometer to test at **multiple positions on the heating plate**. It is normal for the heating plate to have slight heat fluctuations within a few degrees.

About Heat Transfer Vinyl

1. Heat Transfer Vinyl should be cut in reverse from the side that does not have the clear carrier sheet.
2. Before pressing the HTV onto the surface, weed or remove the excess heat transfer vinyl so only the transfer remains on the clear carrier sheet.
3. Flip the HTV transfer onto the surface with the carrier sheet facing up.
4. Lay a thin sheet of teflon over the entire design to protect it during press.
5. Use the recommended pressing time and temperature from the manufacturer based on the heat transfer vinyl you are pressing. Time and temperature will vary depending on brand, finish, and specific material.
6. When the pressing is complete, peel away the clear carrier sheet leaving the transfer on the surface. Do not apply direct heat to the HTV.

**Save 25% off All Siser Heat
Transfer Vinyl (HTV) with
Coupon Code:
SWINGHEATPRESS**

**Save 10% off all Sublimation
Blanks with Coupon Code:
SWINGSUBBLANKS**

Contact Us

Swing Design

support@swingdesign.com

978-371-2211

www.swingdesign.com